

REVISIONS

REV.	DESCRIPTION	DATE	APPRVD.

Notes:

In the event of a power loss, the Noritz unit will not have power to operate the 'internal freeze prevention' electric heater, so water would have to be drained from the system (unit & plumbing) manually to prevent any type of freezing.

An additional method to prevent freezing to the unit, would be by having the solenoid valves in place and wired to 110V supply, water will automatically be supplied to the Noritz only when there is power and water will automatically be drained from the system upon power loss or power outage.

1. 3/4" or bigger Solenoid Valve, normally open, closes upon 110V power loss.

2. Up to 3/4" Solenoid Valve, normally closed. Opens upon 110V power loss.

3. Size the pump to provide a maximum of 2.0 GPM through the system at 10 ft of head plus piping losses. Adjust the flow using a globe valve and verify the flow rate with the maintenance monitors.

4. Pump Control Signal is Noritz's preferred method to control the recirculation pump. For pumps larger than 85W, relay connection should be used. If Noritz pump control is not used, an aquastat may be used to control pump.

5. For residential products, the use of an aquastat is the minimum pump control requirement in order to maintain the full 12-year (or 6500 operational hours) recirculation warranty. An additional timer is also recommended to further reduce the operational hours. See Noritz limited warranty for complete details. Set the aquastat to 10°F below the set output temperature of the water heater.

6. Noritz recommends the use of Isolation Kit (IK-WV-7) with installation. Connections are available in Threaded or Sweat. These kits include an integrated shut-off and service valve with unions and a pressure relief valve.

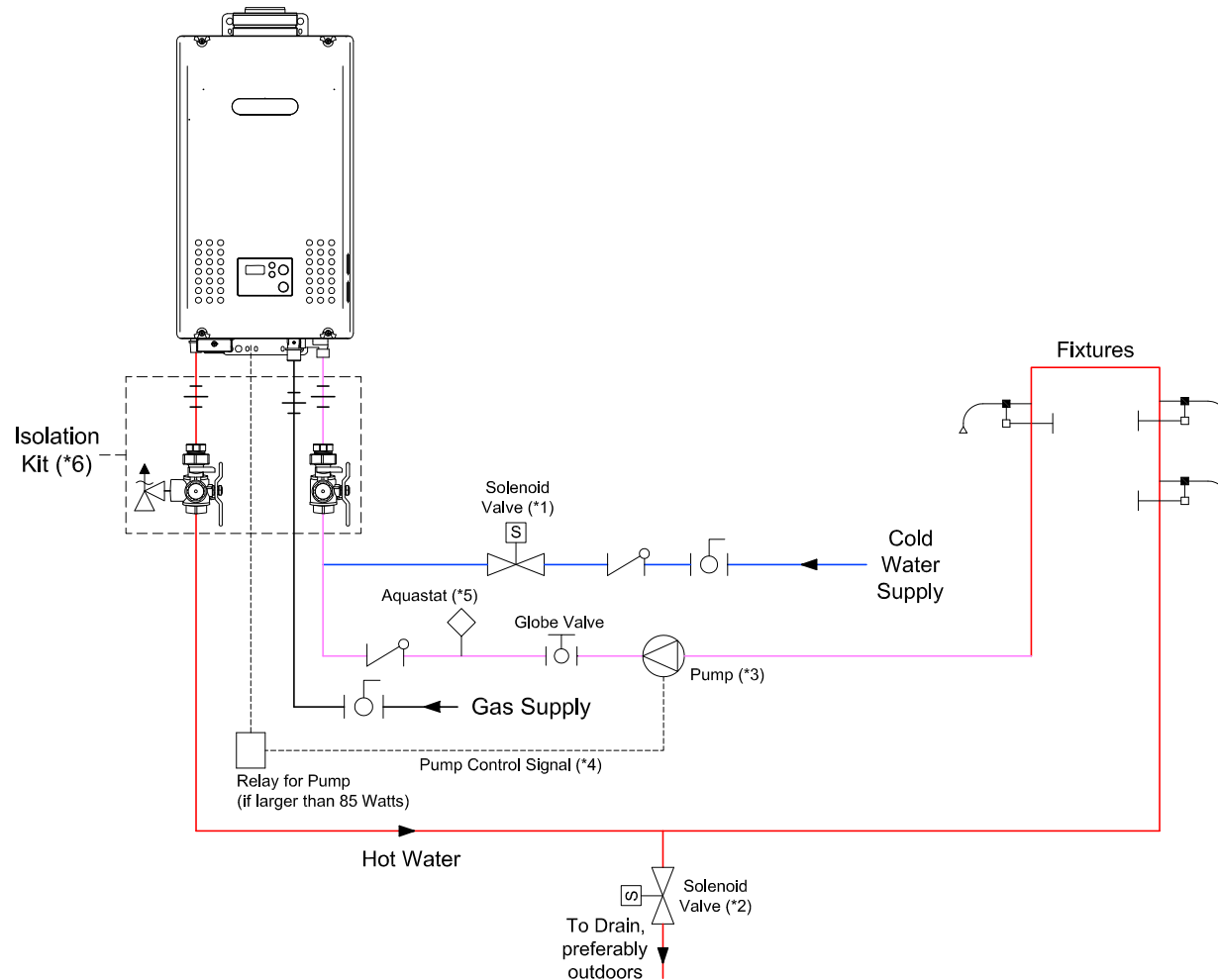

11160 Grace Avenue
Fountain Valley, California 92708
866-7NORITZ (866-766-7489)
www.noritz.com

MODEL:

NR83 Series

APPLICATION:

Domestic Hot Water
Recirculation
Additional Freeze Protection

DRAWING NUMBER:

(9a)NR83

DRAWING DATE:

August 27, 2010

Noritz Accessories

Note: *This diagram is for reference only. Installation must comply with State and Local Code, all gas and water pipe must be sized correctly to specific length, according to accepted engineering methods or the UPC Code for Noritz Water Heaters to operate correctly.*

	Shut-off Ball Valve		Aquastat (Honeywell Model #L6006A or L6006C)
	Check Valve		Pump
	Union		Mixing Valve
	Pressure Relief Valve (Watts 3L, Zurn P1000A, Cash Acme FWL-2)		Thermal Expansion Tank